



Pilot plants & Training plants

Training solutions for the process & energy sector

MMTS

Mechanical Maintenance Training Skid

The training system MMTS is used for the **maintenance of mechanical components** as well as for the **measurement and control of various parameters** in a piping system with two different working media (oil and water). In real applications, such systems can be found in power stations or in facilities for oil refining and natural gas processing.

To simulate the heat input of machines, a heater is used to heat lubricating oil. This heat is dissipated via heat exchanger and cooling water circuit.



Plant at customer's site



Inspection of the plant on site



Components from well-known manufacturers



Assembly at GUNT



On-site briefing by GUNT employees

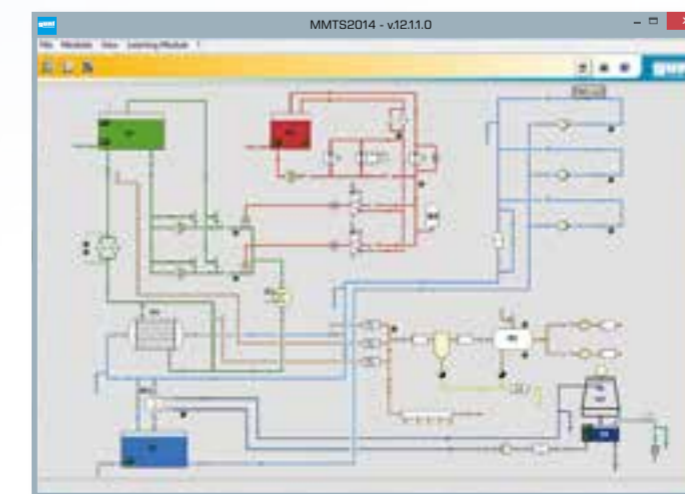

Main screen

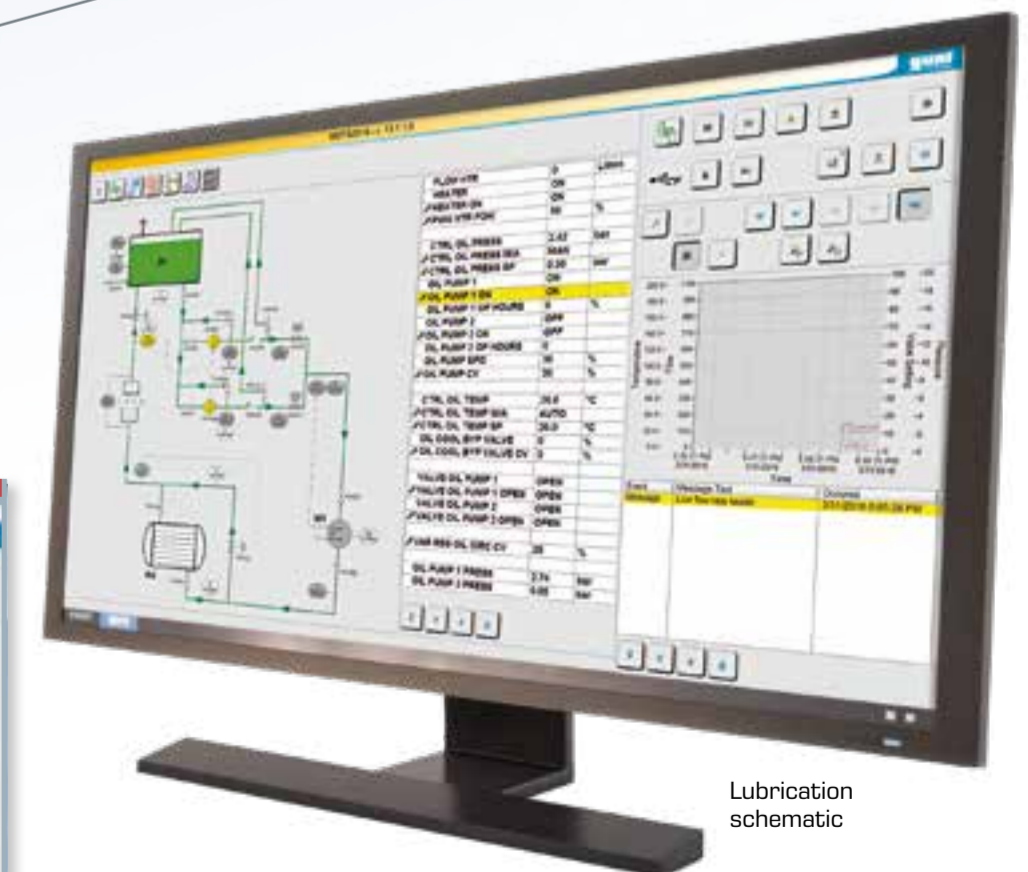

Lubrication schematic

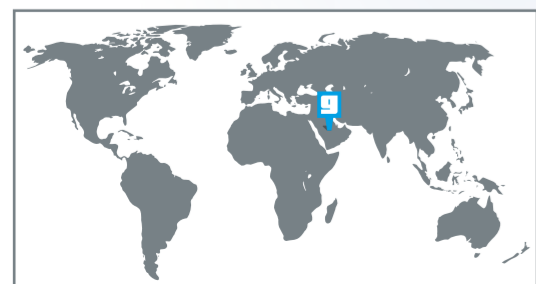

MPTR

Main Process Training Rig

The training rig is based entirely on industrial technologies. It presents a complex project task for training of piping and plant fitters as well as for maintenance technicians. Mechanical, electrical and hydraulic topics can be covered with this rig.

The rig consists of **two units**:

- **Unit 1: Flow control and level control**
- **Unit 2: Flow control, level control and temperature control**

The units work independently of each other. Each unit contains a complete process circuit with pumps, tanks and pipe work including a variety of valves, fittings and measuring instruments. Typical industrial components such as heat exchangers, filters and heaters are also included. Thereby a realistic industrial situation is created.



The operating parameters are monitored with the aid of measuring instruments



Assembly of a pump



With different fittings different operating conditions can be set

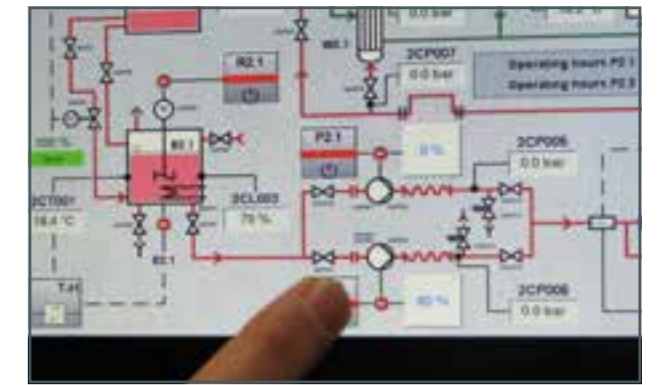

Touchscreen operation on the device can be set



Pumps can be removed and tested



Optionally available pump test bench HM 1000

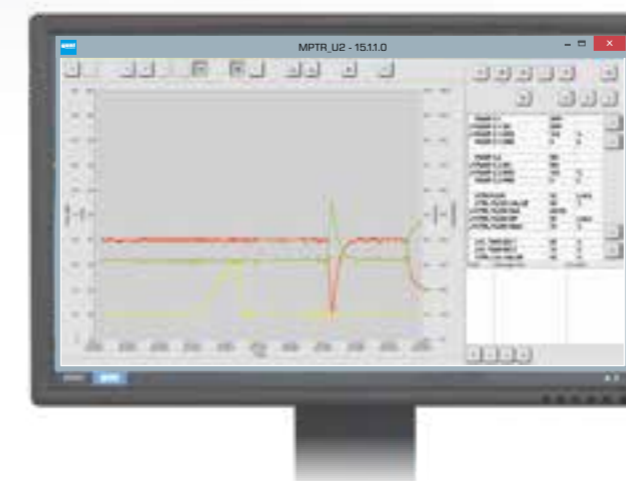

Measured value recording via the software: e.g. recording of measured values over time

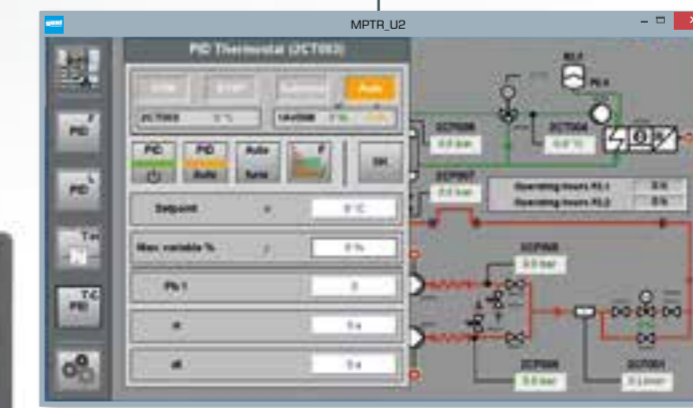

System faults can be simulated

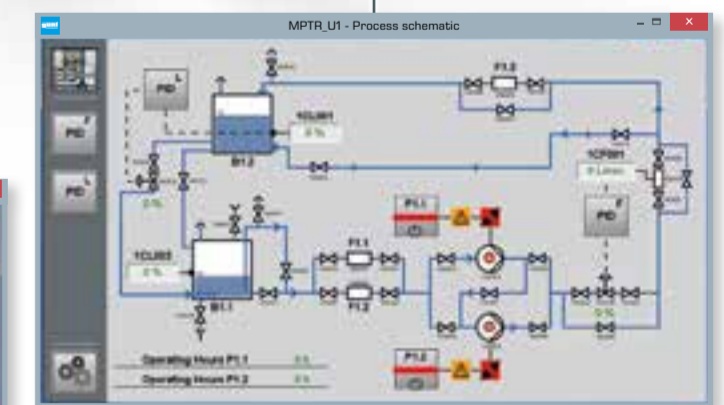

Process diagram



IUI Industrial Unit for Inspection

Knowledge of industrial components plays an important role in the training of industrial inspectors. In order to acquire this knowledge it is very helpful to practice on plants with components in real scale.

The demonstration unit contains various pumps and heat exchangers, a steam turbine and a compressor. The unit consists of three parts: a thermal reactor, a steam driven auxiliary pump and a compressed air station.

All of these parts are connected via pipes and valves. A variety of electrical components such as cables, switches, contactors, displays, fuses and a switch cabinet show typical electrical cabling as in a real-world plant.



Compressed air station



Part of the thermal reactor



Dry cooling tower



Heat exchanger



Assembly of the centrifugal pump on site



15 m

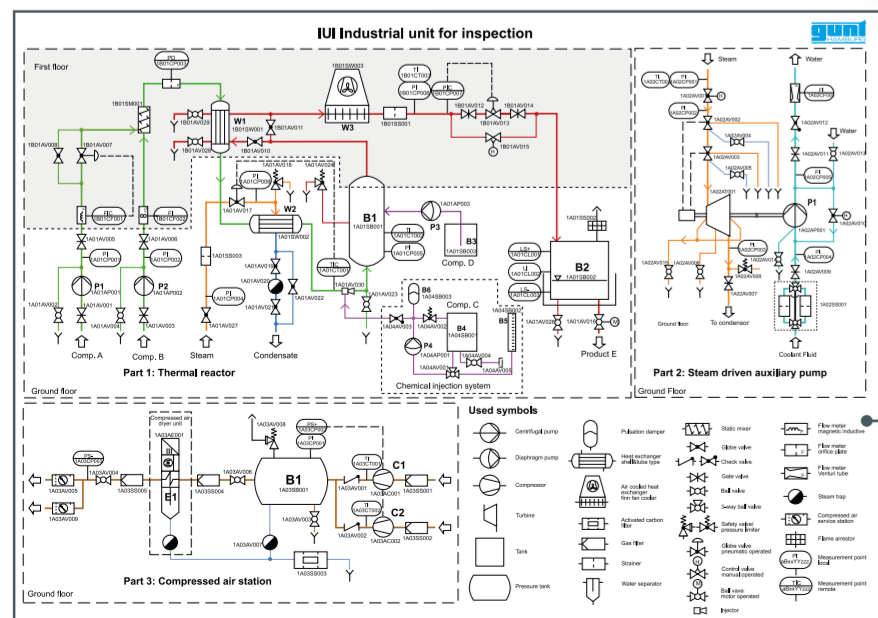

System diagram of the IUI system

Familiarization with technical documentation of plants:

- how to read technical drawings and electrical circuit diagrams?
- how is a process diagram structured?
- what information can be read from a process schema?
- which symbols are used in technical documents?
- which standards and directives/regulations apply?
- which safety regulations apply and how are these implemented and complied with?



Extensive teaching material for IUI plant



Training at the customer's site

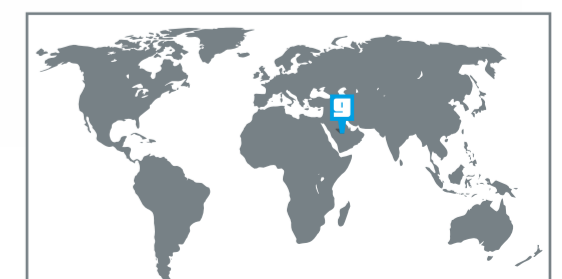

WaXTOT

Wellhead and Xmas-Tree Operation Trainer

WaXTOT demonstrates **pumping a simulated crude oil through a wellhead and X-mas tree**. All details of the plant are on latest industrial level, fully authentic to modern field systems.

- **Wellhead** includes different spools and tubing heads
- **X-mas tree** contains lower and upper master valve, wing valves and choke valves
- **Supply unit** delivers and recycles the synthetic crude oil to ensure its constant composition. It holds water and oil storage tanks, supply pumps for water and oil and separator.

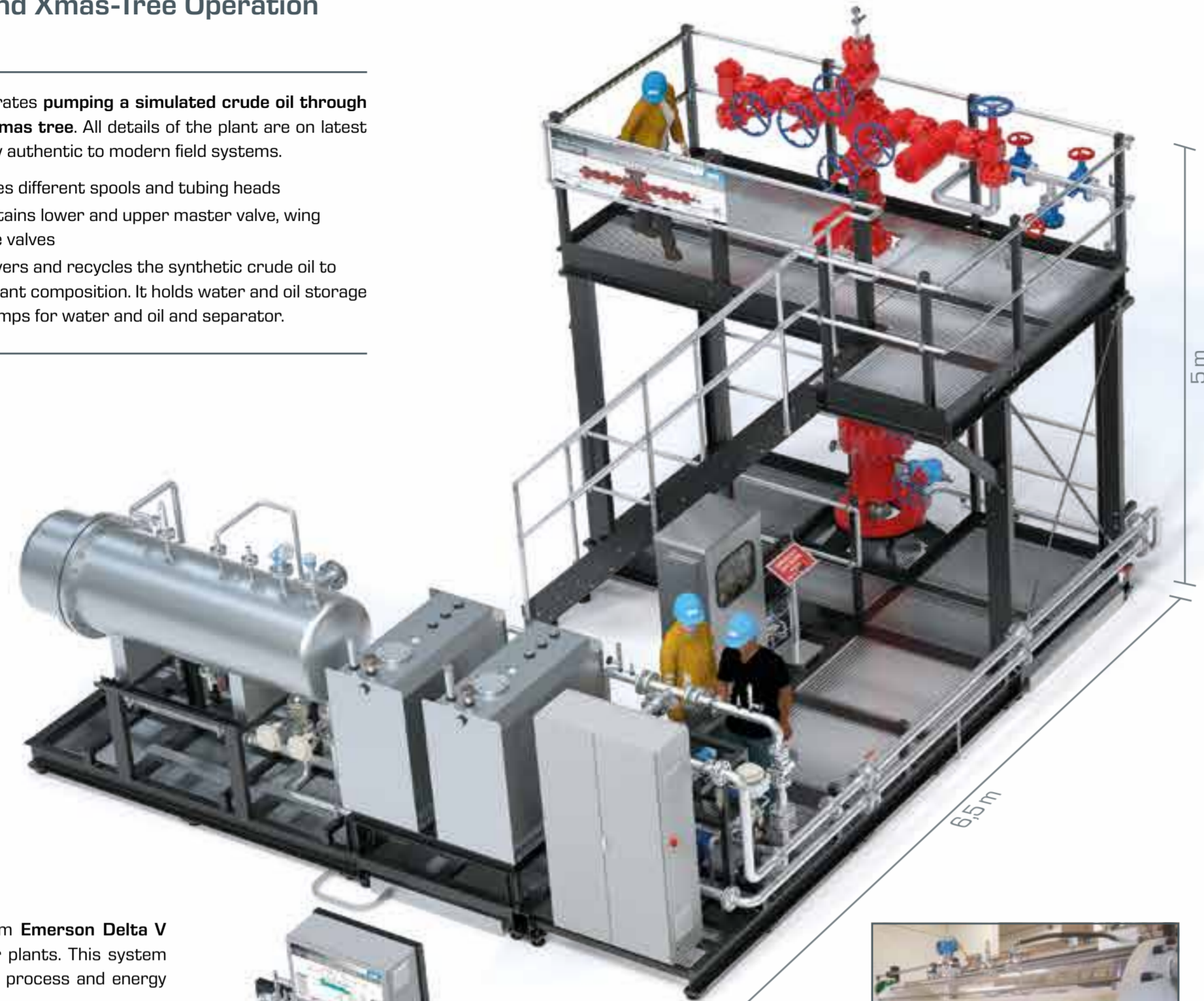

WaXTMT

Wellhead and Xmas-Tree Maintenance Trainer



The intention of the WaXTMT is to show the setup of a wellhead and X-mas tree.

Assembly and disassembly of wellhead and X-mas-tree.

PPT

Process Pump Trainer

In the process pump trainer (PPT) three different pump types are operated and compared in various operation modes. The working medium is a mixture of air, water and oil to simulate crude oil. The trainer consists of **three pump units and one supply unit**. Each pump unit is equipped with two identical pumps. Pump operation in line or parallel is possible.

The used pump types are:

- **Pump unit 1** Single stage centrifugal pumps
- **Pump unit 2** Multistage centrifugal pumps
- **Pump unit 3** Multiphase twin screw pumps

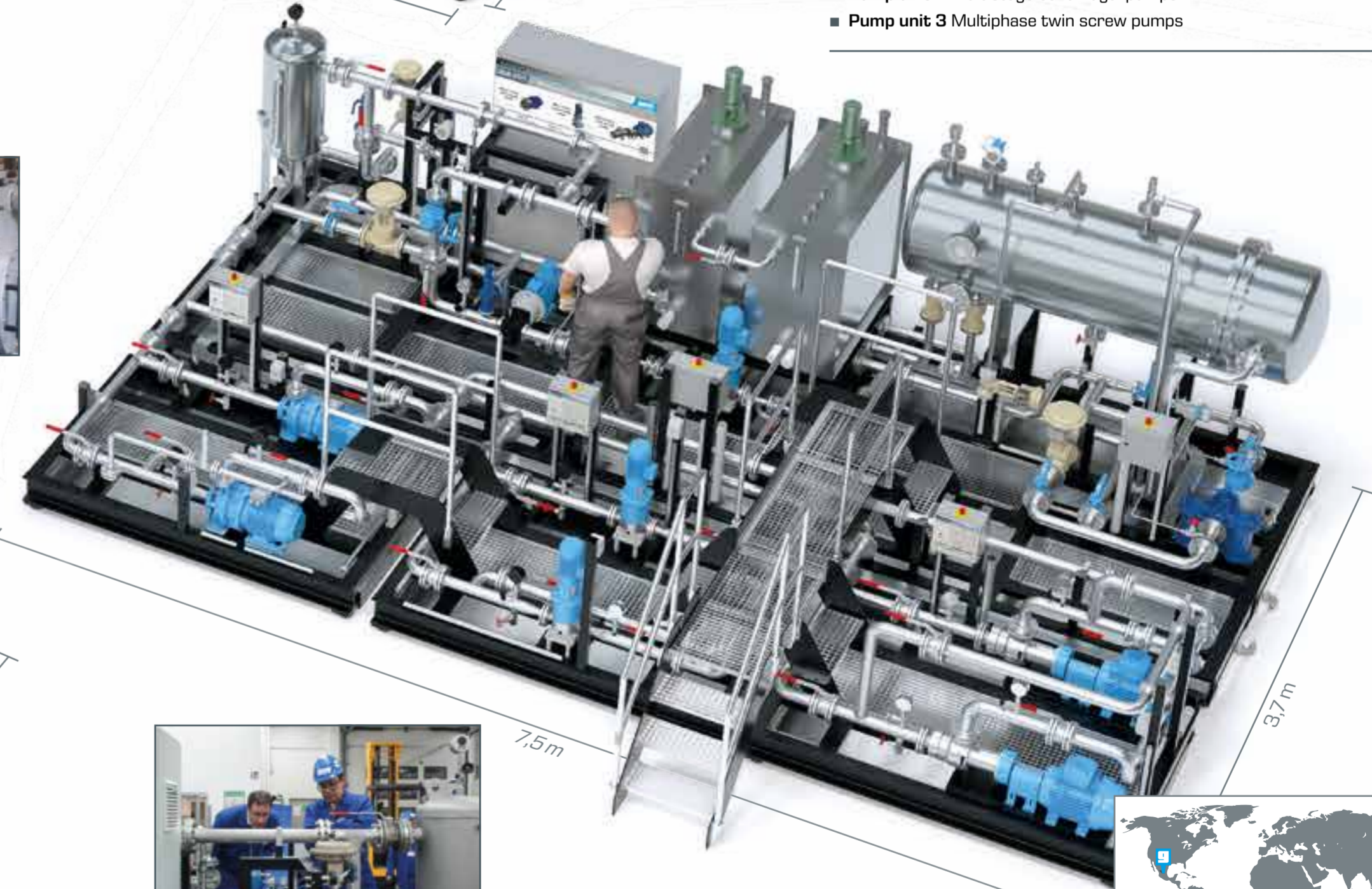

The control system **Emerson Delta V** is used for all four plants. This system is very common in process and energy industry.

PST

Phase Separation Trainer

The phase separation trainer (PST) demonstrates the **separation of simulated crude oil into air, water and oil**. Main part of the trainer is a separator using gravity to split up the simulated crude oil. The separator is **transparent** to enable **observing the separation process**.

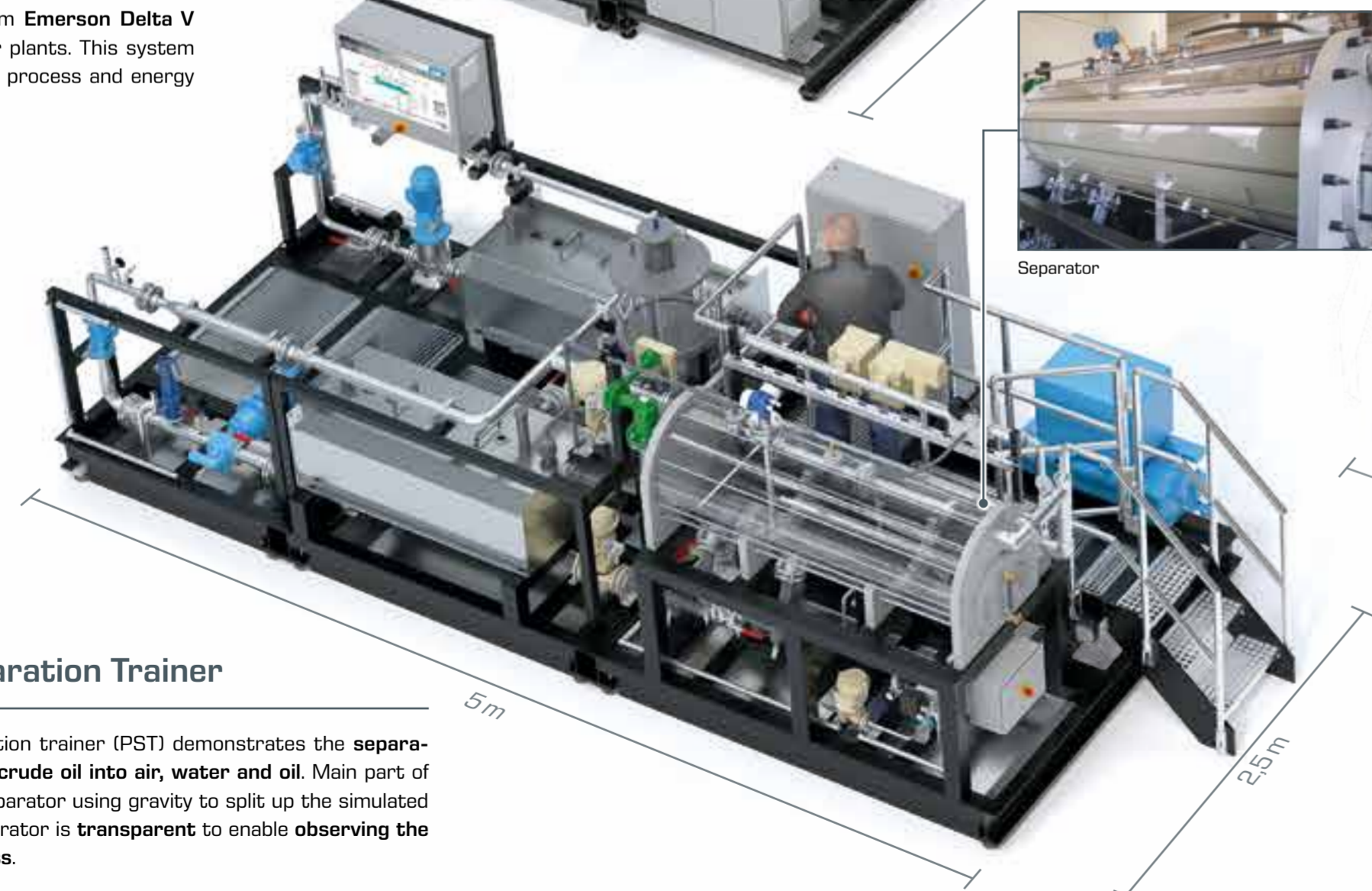

Separator



Last check before shipping



IPP

Integrated Pilot Plant

The IPP demonstrates the operation of a process plant using a water/ethylene glycol mixture as the main medium.

The IPP consists of three units:

- Field Process (FP)
- Distillation Process (DP)
- Utility Unit (UU)

Common process control loops with control variables like temperature, pressure, level and flow rate are part of the **field process**.

Field process and distillation process can be operated separately as well as together.

The **distillation process** separates the water/ethylene glycol mixture into its components. The distillation takes place in a rectification column with several bubble cap trays. The bottom product and the top product are remixed and led back to the field and distillation process. Both require the utility unit to receive their auxiliary media. Important components of the plant are redundant to allow switchover for repair or maintenance work without shutting down the plant.



Inspection



Heat exchanger



Distillation process

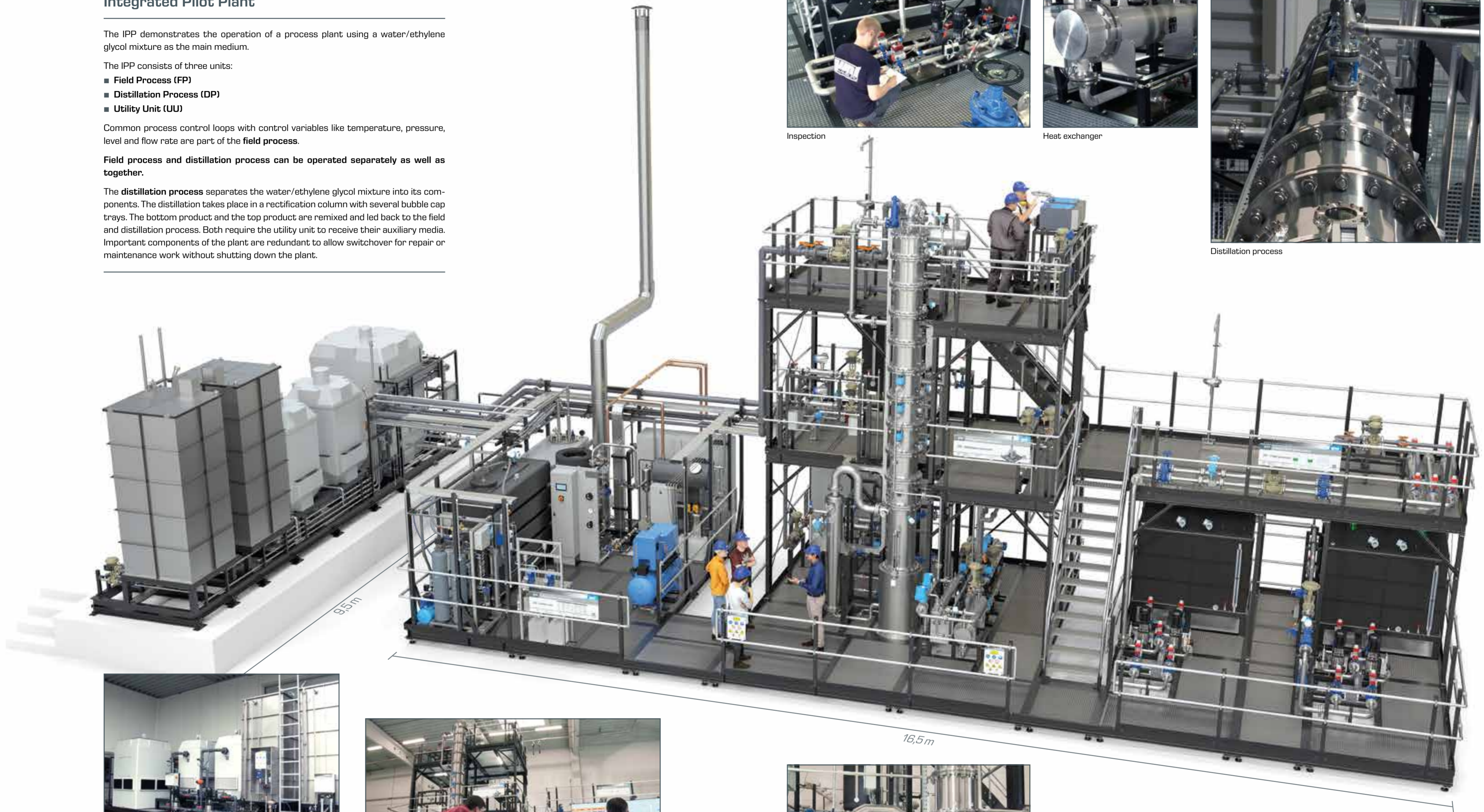

Part of the utility unit



Control station



Steam supply for distillation process

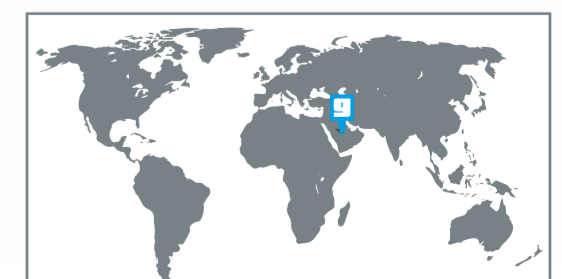

ET 805

Steam power plant 20 kW with process control system

The ET 805 steam turbine is a laboratory scale steam turbine plant consisting of three modules with a closed water circuit.

This unit allows all relevant properties of a steam turbine power plant to be investigated and to be demonstrated by measurements. The integrated process control system (PCS) enables students to practice operation of an automated power plant.

All of the important variables for the process are clearly represented in process diagrams and are converted into characteristic values.

- measurement of all relevant process parameters
- evaluation of the energy equation and the efficiency of the steam boiler, turbine and generator
- determination of the specific fuel consumption
- determination of the saturated steam temperature as a function of pressure
- influence of superheating
- investigation of the condensation process



Setting up the control panel



Turbine

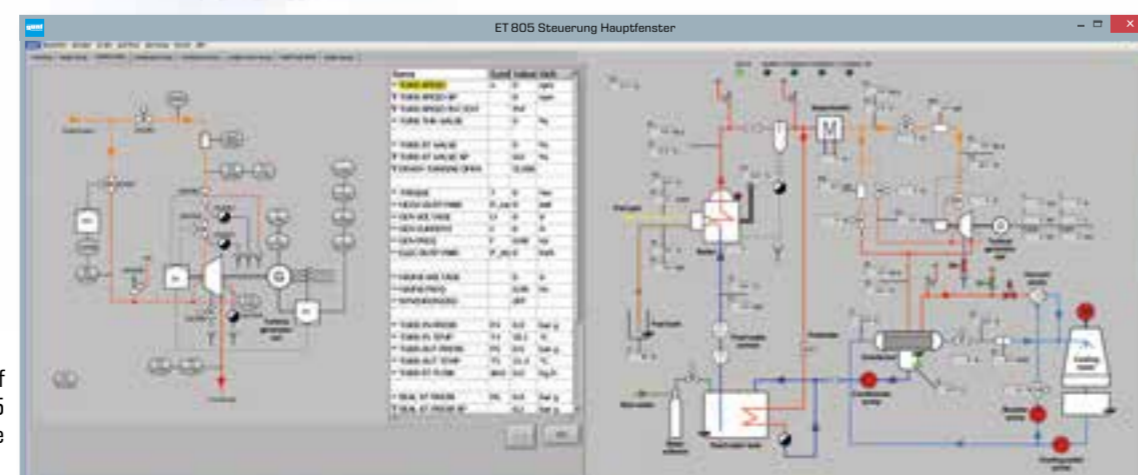
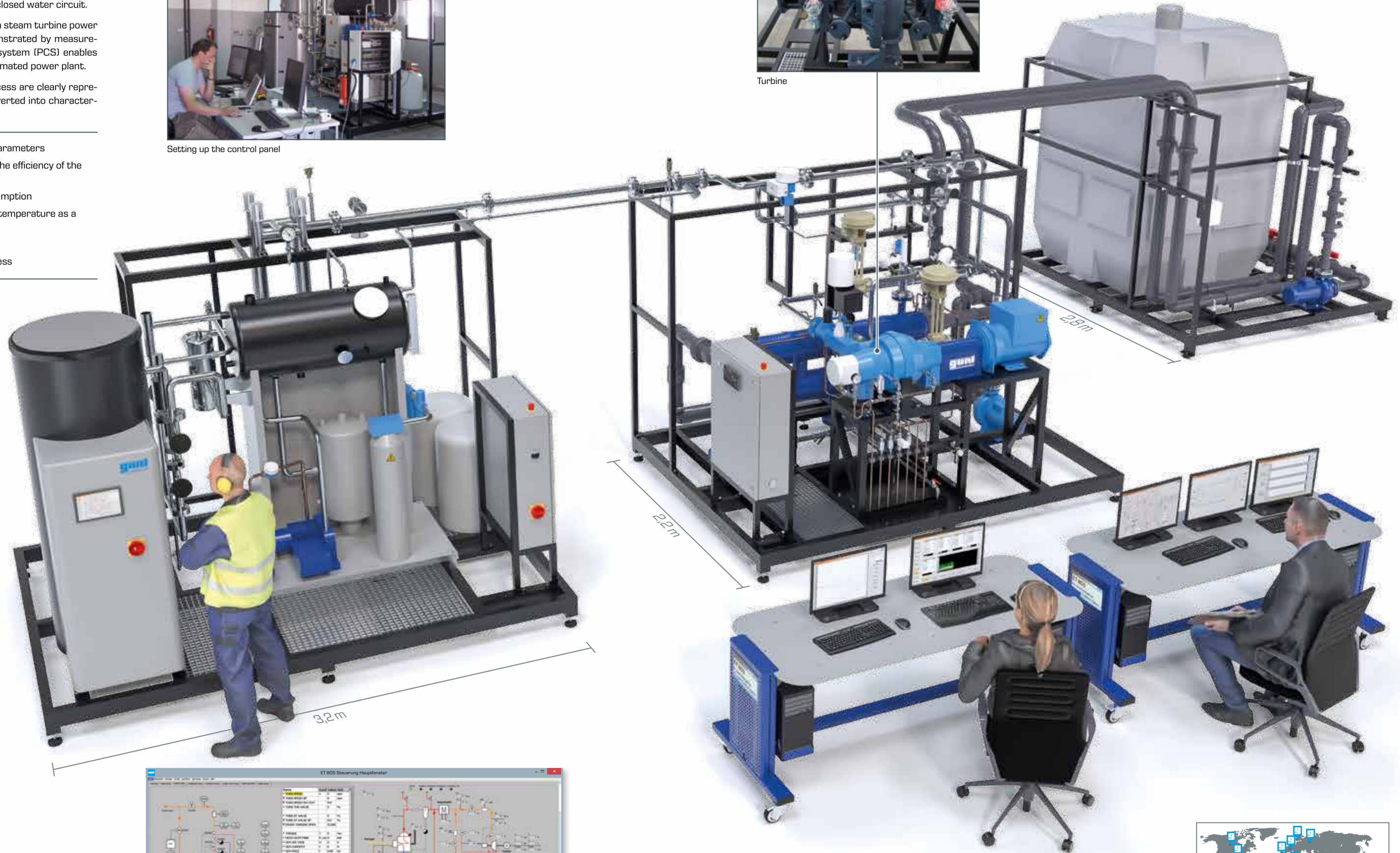

Main screen of the ET 805 GUNT software

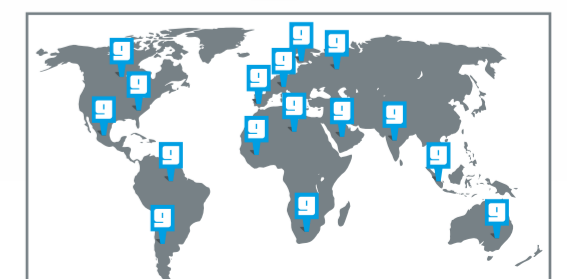

GUNT teaching and training units – with latest real world automation and communication systems

The DeltaV Architecture

Improve plant performance with PlantWeb

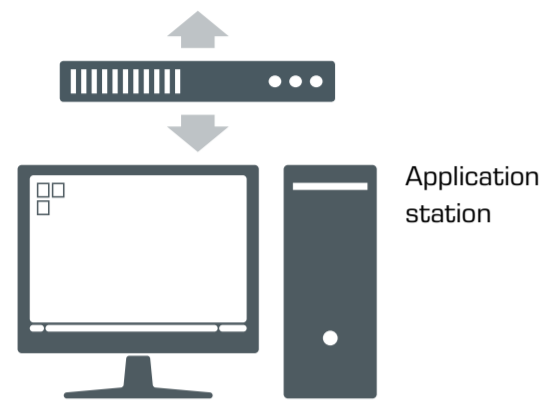

The proven PlantWeb digital plant architecture helps you detect operations, processes, and equipment problems before they even occur, so you can move from reactive to proactive and profitable plant operations.

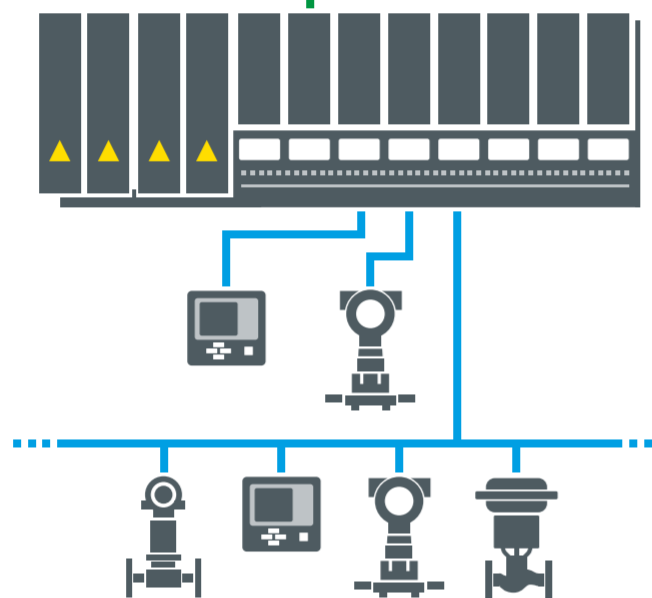

Our devices reproduce industrial reality

The larger the scale of a device, the more realistic the results of the experiment. The smaller the scale, the more flexible the handling of the device. GUNT supplies devices for both cases.



ET 805 control station



MPTR control station

Impressions of training situations



GUNT Technical Academy

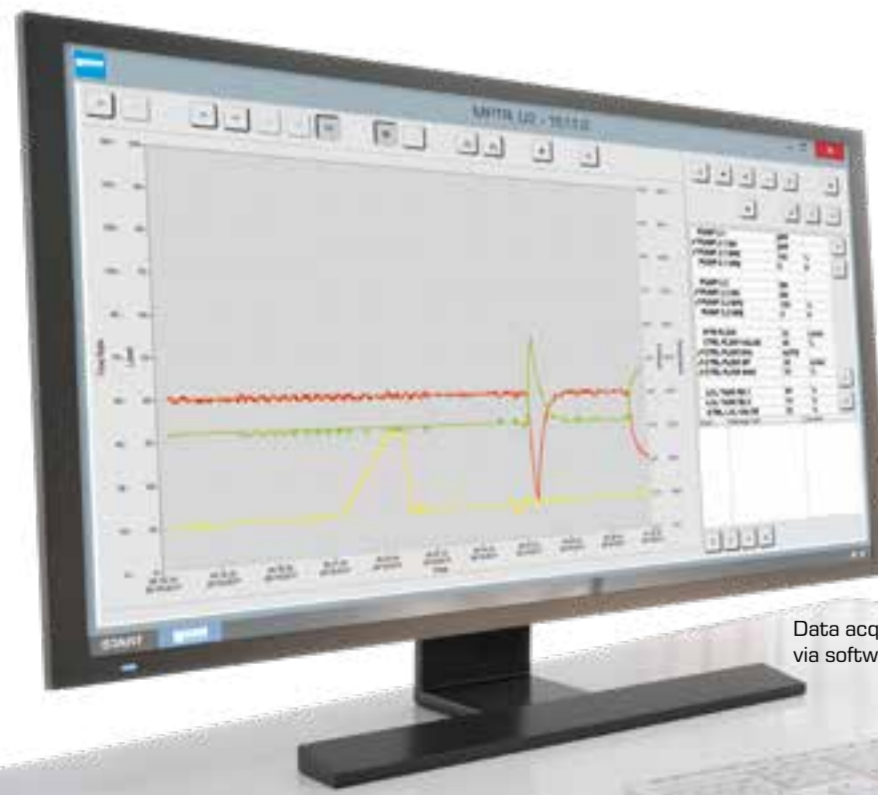

Data acquisition via software: time curve

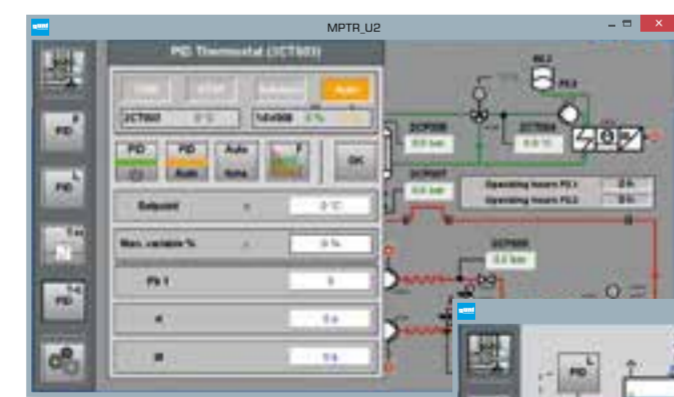

Operation via touchscreen

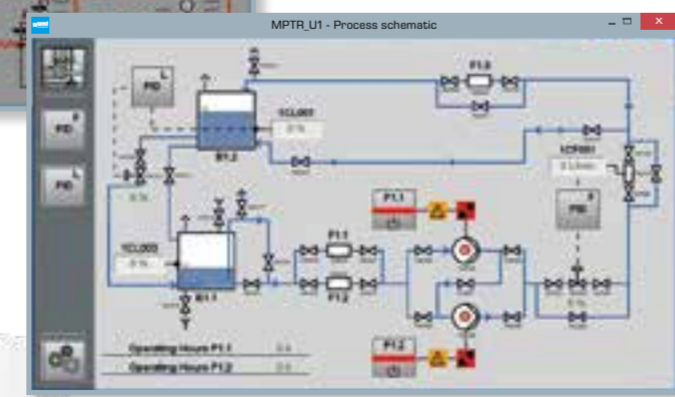

Process schematic

Trainings on your own premises



Instruction by GUNT employees after assembly



Learning outcomes for industrial services and systems:

- get to know layout and technical details of complex industrial systems
- manage and maintain a wide range of commonly encountered industrial systems
- identify and specify the components of industrial systems
- investigate the applications and efficiency of industrial components
- assembly/disassembly of plant and components
- consider interaction of components



GUNT training plants are covering the following subject areas:

- process & chemical engineering
- mechanical and electrical engineering
- instrumentation & process control engineering
- maintenance and operation procedures

Is your company active in another field? Please get in touch with us. We work and plan together with our clients.

GUNT offers custom made solutions.

Imprint

© 2019 G.U.N.T. Gerätebau GmbH.
Any reuse, storage, duplication and reproduction of content – even in extracts – is prohibited without the written approval of G.U.N.T. Gerätebau GmbH. GUNT is a registered trademark. This means GUNT products are protected, and subject to copyright.

No liability can be accepted for any misprints. Subject to change without notice.

Image credits:
G.U.N.T. Gerätebau GmbH.
Design & graphics:
Profisatz.Graphics,
Bianca Buhmann, Hamburg.
Printed on non-chlorinated,
environmentally friendly paper.



G. Systemes Didactiques E. s.a.r.l.

Equipement pour l'enseignement expérimental, scientifique et technique
www.systemes-didactiques.fr

GSDE 181 rue Franz Liszt
F 73000 CHAMBERY
Tél : 04 56 42 80 70 Fax : 04 56 42 80 71
xavier.granjon@systemes-didactiques.fr

Génie Mécanique, Génie Thermique, Génie des Procédés, Mécaniques des fluides,
Physique, Chimie, Modèles anatomiques et végétaux, Microscopes, SVT,
Génie électrique, Automatismes, Régulation, Télécommunications,
Energies renouvelables, Solaire, Piles à Hydrogène, Mobilier



Visit our website
www.gunt.de